



Tecumseh Hermetic Condensing Units

AWA9518ZXNXM

January 2003

Model: AWA9518ZXNXM (2C2133-9) R404A 2 HP AIRCOOLED

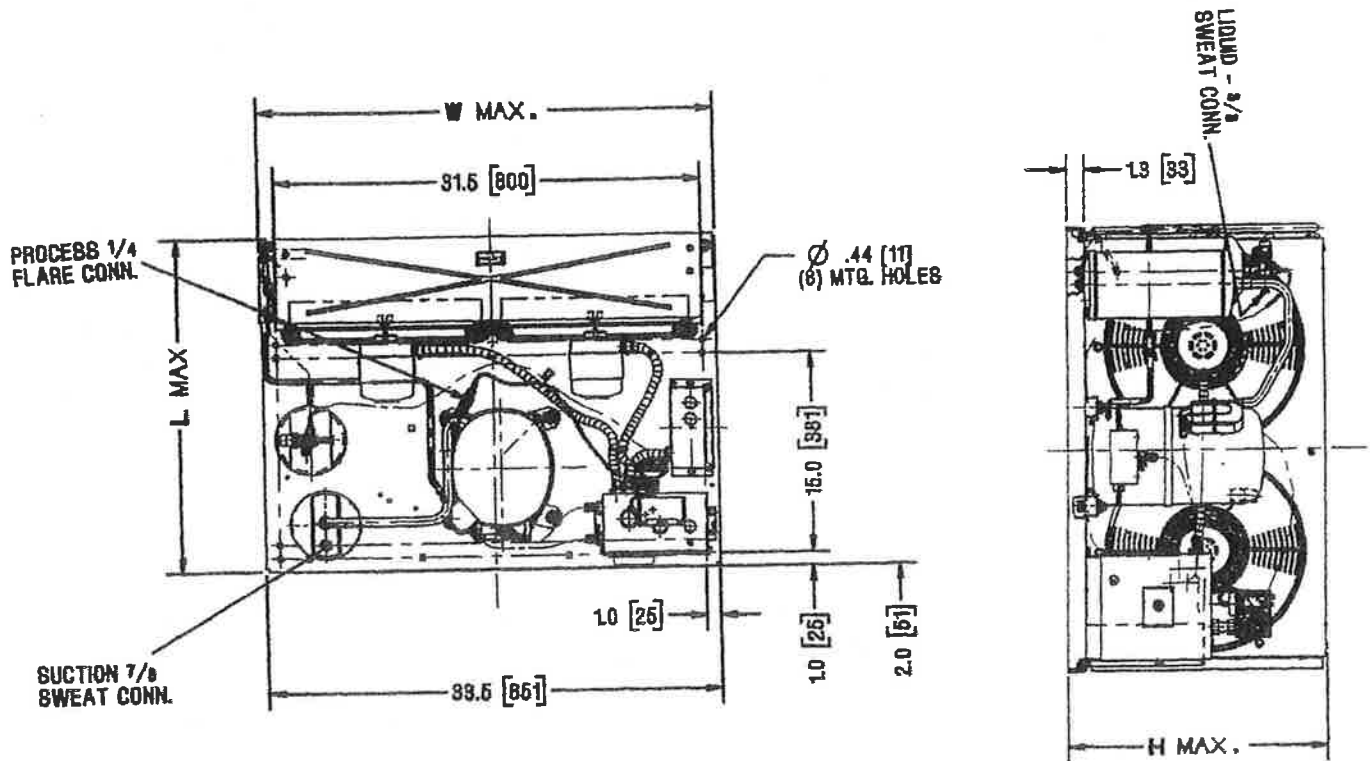

NOTE: DIMENSIONS = INCHES (MILLIMETERS)

Model	Dimensions,"				Line Connection*		Pumpdown	Air	Oil Ch.	Gr. Wt.
	L	W	H	CH	Suction	Liquid	90 °F 90%	CFM	Oz.	Lbs.
AWA9518ZXNXM	25.0	33.48	19.5	14.6	7/8"S	3/8"S	13.8	1525	54	150

*F= Flare, S= Solder, RF or RS = Rotolock with Flare or Solder Connections. C= Compression Fitting
 Factory charge: 20 PSIG Nitrogen – **MUST BE EVACUATED**

60 Hz Performance

Ambient Temps										
Evaporator		90 °F			100 °F			110 °F		
T, °F	PSIG	BTUH	Watts	Head	BTUH	Watts	Head	BTUH	Watts	Head
-10	23.6	8659	1970	238	7287	1933	271	5874	1871	308
0	32.6	11392	2262	248	9822	2252	281	8221	2223	319
5	37.7	12952	2408	253	11255	2410	287	9542	2398	325
10	43.2	14642	2553	260	12800	2569	293	10962	2573	331
15	49.1	16461	2699	266	14456	2726	300	12480	2747	338
20	55.4	18409	2844	273	16224	2883	307	14096	2920	345
30	69.6	22694	3135	289	20091	3196	323	17624	3264	361
35	77.2	25030	3280	298	22192	3352	331	19536	3435	369
40	85.5	27495	3425	307	24403	3507	340	21546	3605	378
45	94.3	30090	3570	316	26726	3662	350	23654	3775	387

Return gas temp. 40°F, 5°F sub cooling

Date: January 2003
 Unit Catalog Update
NEW

SPECIFICATIONS	<u>AWA9518ZXNXM</u>
Nominal Voltage	<u>230/208-1</u>
Unit B/M	<u>2C2133-9</u>
Voltage Range	<u>253 to 187</u>
Min. Circuit Ampacity	<u>21.4</u>
Max. Fuse Size (Amps)	<u>35</u>
Compressor Model	<u>AWA9514ZXN</u>
Comp. Bill of Material	<u>AW617ET-099</u>
RLA/LRA	<u>14.8/90.0</u>
ESP Overload	<u>Internal</u>
ESP Relay	<u>P82965</u>
Capacitor Cabinet	<u>AE1397-006</u>
Control Panel	<u>AC1391-12</u>
Start Capacitor	<u>85PS330D17</u>
Rating	<u>145-175MFD/330V</u>
Run Capacitor	<u>85PR370F21</u>
Rating	<u>45MFD/370V</u>
Fan Switch (s)	<u>84096-1</u>
	<u>84096-2</u>

High Pressure Switch	<u>84095-2</u>
Control	<u>84026-5 (LP)</u>
Contactor	<u>91017 (25 AMP-1PH,230V)</u>
Fan Motor (OEM)	<u>810S050A99</u>
Fan RLA	<u>1.30 RLA</u>
Replacement Motor	<u>TFM502</u>
Fan Blade	<u>51568 (2 req)</u>
Shroud	<u>70648-2</u>
Condenser	<u>K42-17</u>
Fan Guard	<u>70831 (2 req)</u>
Receiver Tank	<u>51081-1</u>
Receiver Tank Valve	<u>31581-1 (3/8" S) RL</u>
O' Ring Gasket	<u>30334</u>
Process Valve	<u>31583-1 (1/4"F PV)</u>
Optional Outdoor Enclosure	<u>TP-181D</u>
Crankcase Heater (If Inc)	<u>91022-1</u>
Accumulator	<u>TK00042000</u>
Unit Drawing	<u>SU1918-1</u>
Schematic or Elect. Drawing	<u>91028</u>

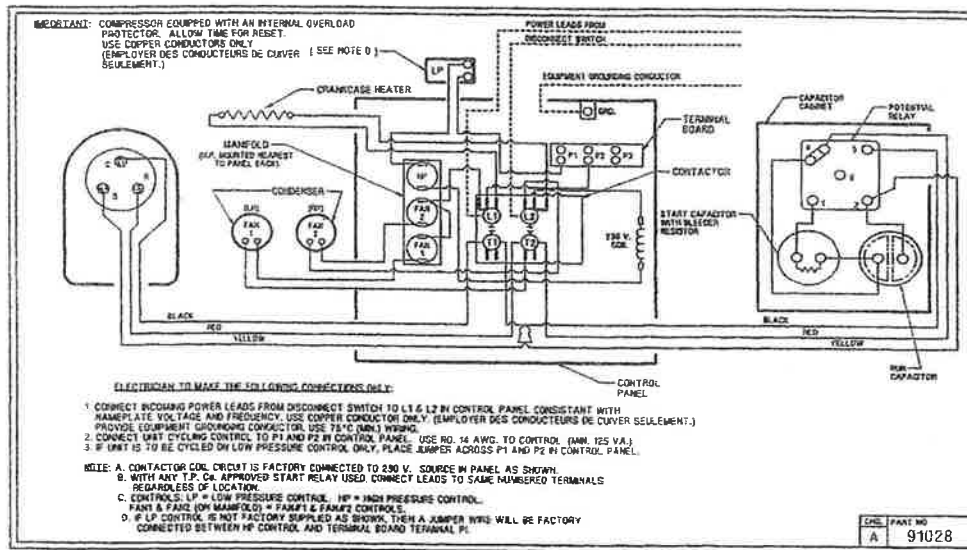

Some parts listed may be optional or listed as replacement parts.