



Tecumseh Products Company Hermetic Condensing Units

Model: AWA9511ZXTXC
B/M 2B1140-9

R-404A

1 ¼ HP

AIRCOOLED

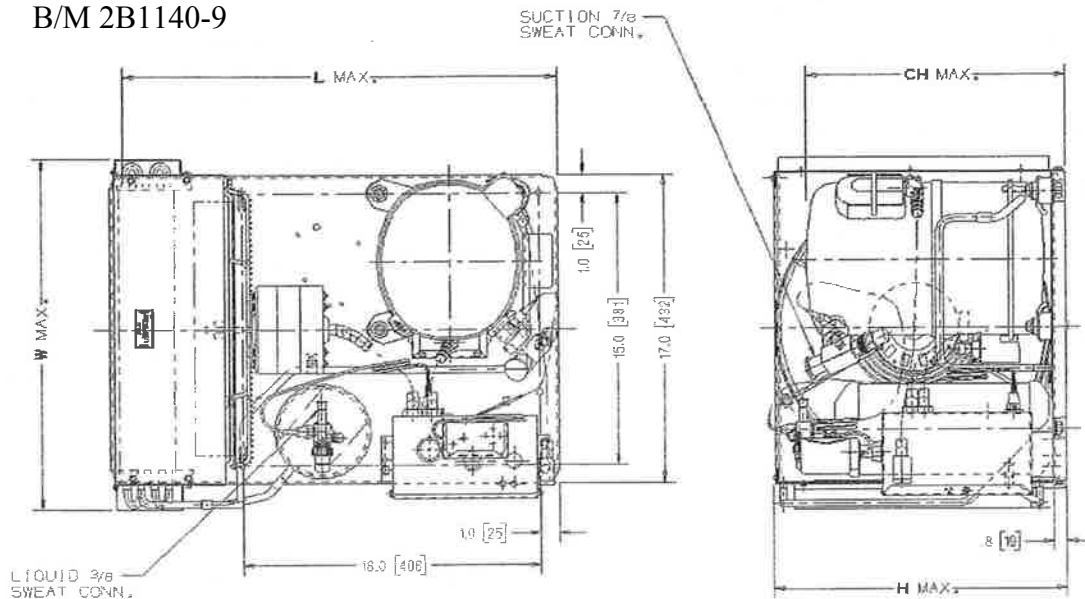

Note: Dimensioning = Inches [mm]

Model	Dimensions, inches				Line Connection*		Pumpdown	Air	Oil Ch	Gr. Wt.
	L	W	H	CH	Suction	Liquid	90% @ 90°F	SCFM	cc	Lbs.
AWA9511ZXTXC	24.0	19.4	16.2	15.6	7/8" RF	3/8" RF	11.6 lbs	754	1141	130

* F = Flare, S = Solder, RF or RS = Rotolock with Flare or Solder Connections, C = Compression Fitting
 Factory charge: 20 PSIG Nitrogen – **MUST BE EVACUATED**

60 Hz Performance

Evaporator	Ambient Temperatures																	
	F PSI		80 deg F				90 deg F				100 deg F				110 deg F			
			BTUH	Watts	Head	Cond T	BTUH	Watts	Head	Cond T	BTUH	Watts	Head	Cond T	BTUH	Watts	Head	Cond T
-10	23.2	5958	1253	213	92	4917	1224	243	101	4695	1243	274	109	3716	1146	310	119	
-5	27.5	6780	1335	220	94	5716	1318	250	103	5249	1330	282	112	4203	1253	317	121	
0	32.1	7686	1419	227	96	6585	1413	257	105	5886	1420	290	114	4769	1361	325	122	
5	37.0	8676	1507	236	98	7523	1511	266	107	6605	1515	298	116	5413	1472	333	124	
10	42.4	9750	1596	245	101	8529	1610	275	109	7407	1612	308	118	6135	1584	342	126	
15	48.2	10908	1689	254	103	9605	1712	284	112	8292	1714	318	120	6936	1699	352	128	
20	54.5	12150	1784	265	106	10750	1815	295	114	9259	1819	328	123	7816	1815	362	130	
25	61.2	13476	1881	276	108	11964	1919	306	117	10310	1927	340	125	8774	1933	373	133	
30	68.4	14886	1982	288	111	13248	2026	318	119	11443	2039	352	128	9810	2054	385	135	
35	76.1	16380	2085	301	114	14600	2134	331	122	12659	2155	365	130	10925	2176	397	137	
40	84.4	17958	2190	314	117	16021	2244	344	125	13958	2274	378	133	12118	2301	410	140	
45	93.2	19620	2299	328	120	17512	2356	358	128	15339	2398	392	135	13390	2427	424	142	
50	103.0	21366	2410	343	123	19071	2470	373	131	16803	2524	407	138	14740	2556	438	145	
55	113.0	23196	2523	359	126	20700	2586	389	134	18350	2654	423	141	-	-	-	-	

Return gas temp. 40°F, 5°F sub cooling

Specifications: AWA9511ZXTXC

Model	AWA9511ZXTXC
Nominal Volts-Hz-Ph	200-230/60/3; 200-220/50/3
Unit Bill of Material	2B1140-9
Voltage Range	180 to 253 Volts
Min. Circuit Ampacity	9.9 Amps
Max. Fuse Size	15 Amps
Compressor Model	AWA9490ZXT
Comp. Bill of Material	AW616rT-121-P2
Compressor RLA/LRA	6.7 / 51.0 Amps
Overload	Internal
Fan Motor	810S050A99
Fan RLA	1.30 Amps
Fan Control Switch	N/A
Unit Drawing	SU1918-3
Electrical Drawing	91029-1

Condenser	50857-1
Receiver Tank	51081-1
Liquid Rotolock Valve	31581-1 (3/8" Sweat Rotolock)
Suction Rotolock Valve	31529-1 (7/8" Sweat Rotolock)
Accumulator	N/A
High Pressure Control	84097-3
Low Pressure Control	84026-5 or 84026-2
Contactor	91014 (30Amps, 230 Volt, 3Ø)
Crankcase Heater	91022-1 (230 Volt)
Fan Blade	51568-1
Fan Guard	70831
Low Side Design Pressure	181 PSIG
High Side Design Pressure	450 PSIG
Packaging	Single Unit in a Box

